

## Behind the Scenes

By Janet Carman

The Museum of Cheyenne County is a busy place. As you pass by on U.S. 36, you may notice several cars parked there. Tourists may be visiting or volunteers may be at work inside.

In April, 70 guests attended an open house honoring those who had helped establish and maintain the museum. In March, Margaret Bucholtz volunteered to open the museum Tuesdays through Fridays from 1 to 4 p.m. Because Mrs. Bucholtz works many more hours at home organizing and scanning old photos, researching genealogies and editing historical DVDs, the board decided to appoint her as museum director.

Thanks to volunteers, the museum was open all day during the June Stearman Fly-In. Special exhibits, featuring Ron Evans and Charles Lindberg, attracted flight enthusiasts.

Several classes toured the museum or met in Ye Olde Country Church during alumni weekend.

Tuesday, July 5, several volun-

teers inventoried all items in the museum. Volunteers are continuing the work of matching accession records to inventoried items. Letters have been sent out to donors whose paperwork was missing. Donors have been asked to sign and return the donor form.

The director and volunteers are working to conform with standard museum policy by accepting donations and not loans. Young volunteers are working to input data into computer records.

There is a tremendous need for museum volunteers. Volunteer once a week, or just once a month. You'll love it!

Museum hours are Tuesday through Friday from 1 to 4. If you want to tour or even volunteer after hours, just call a board member. They will be eager to open the door for you. Phone numbers are posted on the door. Board members are Stan Carman (332 3569), Deb Harper (332-2336), Dee Dorsch (734-2785), Rachel Huffman (332 2600), Lucille Rossbach (332 8903).

## Board recognizes new members

The Northwest Kansas Technical College, Goodland, held its annual meeting of the Area Advisory Board on July 28 in the board room on the college campus with a quorum of 18 members in attendance.

This annual meeting is when the board reorganizes with any new members and the nine-member Area Board of Control is elected.

Officers and committee chairmen elected were: Robert Loftin, Weskan, chairman; Frank Otter, Norton, vice chairman; Marvin Sprenkel, Quinter, treasurer; Mark Smith, Tribune, secretary. Various committee chairmen included: Chair Legere, Hill City; Billi Beckman, Hoxie; Paul Bruggeman, Rexford; Bruce Buck, Sharon Springs and Arlie Archer, Cheylin. Archer is the Student Welfare Committee Chair.

Other members of the board were named to committees such as the Building and Grounds Committee, Curriculum Committee, Faculty Committee, Public Rela-

tions Committee and Student Welfare Committee. Myra Douthit of St. Francis is a member of the Curriculum Committee.

Prior to the election of officers, each current officer of the Area Board of Control gave a report on the 2006-07 activities.

The officers noted that the Respiratory Therapy program will be a great addition to the college.

The diesel renovation and the goal to provide on-campus daycare are also very exciting, but the goal of achieving Higher Learning Commission Accreditation and all the hard work done by the faculty and staff tops off another successful year.

The Technical College offers a variety of programs to receive associate of applied science degrees and technical certificates.

There are 24 United School Districts that are participating districts with the Northwest Kansas Technical College including Cheylin and St. Francis.



"LOCKS OF LOVE" ceremony was held Saturday during the eighth annual American Cancer Society Relay for Life. Those donating hair to 'Locks of Love' individuals have at least 10 inches of hair to be cut and donate that hair for wigs

for cancer survivors. Left, Katie Schmid sat quietly while Leisha Hilt cut her hair and on the right Leroy Bishop also had Mrs. Hilt cut his hair. Several others also had their hair cut.

Herald staff photo by Karen Krien

# Co-op receives rural business grant

By Mary Holle

### Rawlins County Square Deal

The newly formed High Plains Food Co-op, a loosely knit group of livestock producers, consumers and farmers, recently received good news that boosts their efforts to have an up-and-running web-based cooperative by next spring.

The cooperative was awarded a \$40,000 rural business enterprise grant from the United States Department of Agriculture Rural Development program. Plus, the Rocky Mountain Farmers Union, the co-op's sponsoring organization, will donate \$23,000 in matching funds.

"We are hoping this grant can be a catalyst to help the co-op get off the ground," said Bob Mailander, director of the Rocky Mountain Farmers Union Cooperative Development Center. "The grant will be used basically for two things...one is for a feasibility business plan and market study and two, for connecting consumer groups with producers."

"We need a person to work with four structures - production, storage, packaging and transportation," he continued. "We will also be

looking for an efficient way to move the product from the plains to the target market in the front range."

The grant money is good news for the fledgling cooperative. Organizers have had the idea of an area food cooperative on the back burner for several years.

Wanting to provide farmers with another income source by direct marketing their products is one of the hopes of the Cooperative Development Center's director.

### Co-op history

Chris and Sherri Schmidt brought the idea of a food cooperative home to Rawlins County after attending a weekend meeting in Lindsborg in the spring of 2005. A year later, Rocky Mountain Farmers Union, the Ogallala Commons, Rawlins County HomeTown Competitiveness and Rawlins County Economic Development held a food workshop in March in Atwood.

Another year passed and more people became intrigued with the idea.

Rawlins County Economic Development director, Chris Sramek, helped Mailander and Ogallala Commons director, Darryl Birkenfeld, contact area producers,

food services personnel and consumers for an organizational meeting.

About 30 people from several communities in northwest Kansas and northeast Colorado attended the March 29 meeting in Atwood.

Jo Hagney and Becky Roberson of St. Francis agreed to be co-chairman of the High Plains Food Co-op Steering Committee. The committee has been alternating monthly meeting sites between St. Francis and Atwood since that time.

### Monthly meeting update

Details concerning delivery, distribution, producer surveys and target areas were discussed at the July 19 meeting in Atwood.

Mr. Mailander told the group that the grant will also assist in helping pay for the update to the software program that will be used by Co-op. The software was created by the Oklahoma Food Co-op and provided for free to other food cooperatives.

The Co-op will need to update the software, but it is also usable as is, said Vicki Hunnicutt-Bishara of the Weston A. Price Foundation in Denver.

Mr. Sramek suggested using the

domain name now and providing information on the reserved web page as a tool for recruiting more producers.

"We need to get the web page up as soon as possible to explain the story of the Co-op," he said.

Mr. Sramek suggested that anyone interested in providing products for the Co-op should contact him at 785-626-3640 for more information. The committees next meeting will be in Yuma where the group will meet with several consumer groups.

(Published in the Saint Francis Herald, St. Francis, Kansas and the Bird City Times, Bird City, Kansas) (34)

State of Kansas  
City/County  
2008

### Notice of Budget Hearing

The governing body of CHEYENNE COUNTY, KANSAS will meet on the 31st day of August, 2007 at 9:00 A.M., at the County Courthouse for the purpose of hearing and answering objections of taxpayers relating to the proposed use of all funds and the amount of ad valorem tax. Detailed budget information is available at the COUNTY CLERK'S OFFICE and will be available at this hearing.

### Budget Summary

Proposed Budget 2008 Expenditures and Amount of 2007 Ad Valorem Tax establish the maximum limits of the 2008 budget. Estimated Tax Rate\* is subject to change depending the final assessed valuation.

Fund	2006		2007		PROPOSED BUDGET 2008		
	Prior Year Actual Expenditures	Actual Tax Rate*	Current Year Estimate of Expenditures	Actual Tax Rate*	Expenditures	Amount of 2007 Ad Valorem Tax	Est. Tax Rate*
General	1,682,852	26.245	1,664,674	21.862	1,955,048	1,222,894	31.325
Road and Bridge	829,453	11.293	978,200	16.221	922,880	370,717	9.496
Bridge Building	71,958	0.840	15,987	0.057	85,000	84,820	2.173
Noxious Weed	35,109	0.556	37,100	0.665	34,790	16,843	0.431
Bond and Interest	303,880	5.569	307,500	5.353	27,308	0	0.000
Hospital	527,582	5.625	525,000	6.560	525,000	223,109	5.715
Prairie Dog	13,262		11,500				
Special Parks & Recreation	700		1,100			3,408	
Special Alcohol	3,110		1,000			4,896	
Health Grants	27,650		20,000			43,712	
Special Machinery	176,071						
Noxious Weed Capital Outlay	0						
Spec Ambulance Cap Outlay	0						
Equipment Reserve	37,156						
Multi-Year Capital Improvement	0						
Motor Vehicle Fund	20,934		27,415			31,254	
Totals	3,729,717	50.128	3,589,476	50.718	3,644,042	1,918,384	49.140
Less: Transfers	249,744		214,500			214,308	
Net Expenditures	3,479,973		3,374,976			3,429,734	
Total Tax Levied	1,398,097		2,204,149				
Assessed Valuation	40,501,431		43,460,833			39,039,310	
Outstanding Indebtedness, January 1							
2005                      2006                      2007							
GO Bonds	925,200		636,000			336,800	
Lease-Purchase	0		0			0	
Total	925,200		636,000			336,800	
Fire Districts:							
No. 1 - General	51,310	1.172	33,400	1.164	38,000	24,123	0.823
No. 1 - Equip Reserve	0						
No. 1 - Special Equip	0						

\*Tax Rates are expressed in mills.

Terry Miller  
Clerk

## Call Us for a Dealer Near You!

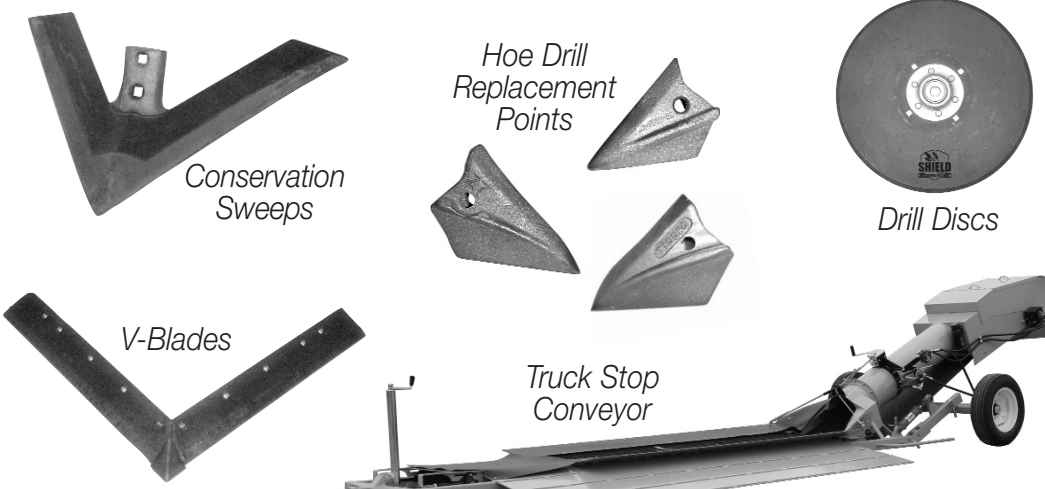

(800) 798-1968

PO Box 687 • Hutchinson, KS 67504-0687 • (620) 662-7482 Fax

shieldag.com • shieldagconveyors.com • acraplant.com

## WANTED Bird City Times Associate-Editor

Looking for an energetic person, living in the Bird City area. The applicant must have some computer, writing and some photography skills, get along well with customers, be able to cover meetings, school activities and other happenings within the communities of Bird City and McDonald.

To apply or for more information, contact Casey McCormick or Karen Krien at the St. Francis Herald, 785-332-3162 or stop by the office at 310 W. Washington, St. Francis.