

# 18th ANNUAL

# Harvest Countdown

## \$100 in spendable scrip money!

Register as often as you like at all participating businesses!

## — Contest Rules —

1. Winner is the entry which comes closest to guessing the day, hour and minute the first load of 2003 wheat arrives at one of the participating grain elevators with moisture content of 14 percent or less:
2. Entry guesses may be made only at participating businesses advertised on these pages. Look for the sign in the window of participating business places and sign up at their service counters. No purchase necessary to win. Check their merchandise and services while you are there!
3. Winners will receive the following amounts in scrip money good at any of these fine places of business:  
**1st prize: \$50; 2nd prize: \$35; 3rd prize: \$15.**
4. Persons age 18 or older are eligible to enter.
5. Deadline for entries: 4 p.m., Friday, June 20, or when the first load arrives, if earlier.

6. Previous winners and previous first loads are ineligible, as are employees and relatives of *The Oberlin Herald*.

Participating elevators are:

**Decatur COOP Assn.**

Oberlin — Jennings — Kanona — Herndon  
Ludell — Danbury, NE — Edmond

**Hansen-Mueller**  
Oberlin — Cedar Bluffs

**Hi-Plains Co-op**  
Selden



**Personalized**  
Grain Merchandising  
Service  
There when you need us

Hansen-Mueller Co., Oberlin is ready to give bids and offers on wheat, corn, milo, and beans. For specialty crops, call for a quote. At Hansen-Mueller, we are dedicated to providing personalized service and an individualized approach to grain merchandising. Utilizing the latest technology, we provide full service grain merchandising throughout the world.

**For Feed Yard Offers: For Elevator Bids:**

**JP Worcester Bill Gotchall**  
800-383-6736 785-475-3116



## WEATHERING THE STORMS SINCE 1893.

More than four generations of farmers have trusted Farmers Mutual Hail. That's just one reason we're the respected leader in the industry. Want more reasons? Call your local Farmers Mutual Hail agent.

**Decatur County Title & Abstract Co.**

*We sell Crop Insurance you can depend on.*  
181 S. Penn — Oberlin, Kan. 67749  
Phone: 785-475-2381 — Fax: 785-475-3556

Look For The Cloud  
Farmers Mutual Hail Insurance Company

### For All Your Harvest Needs...

With our store you get more room, greater selection, new products and expanded services. Pick up your favorite deli sandwiches, cold drinks, ice, fresh fruit, snacks, beer, lottery tickets, money orders... anything you need for that fast, hectic pace of harvest.

*The only thing that stays the same is our friendly hometown service. Stop in to shop today!*

**Fresh Daily Bakery**  
Delicious goodies fresh daily. Breads, pies, sweet treats. All your favorites.

**RAYE'S GROCERY**

119 W. COMMERCIAL-OBERLIN (785) 475-2952



Save everyday on Good Neighbor Pharmacy Brand Products  
See our sales circular in the June 4 newspaper

**WARD DRUG STORE**

**Good Neighbor Pharmacy** Kurt Vollertsen  
142 S. Penn, Oberlin - 785-475-2285 1-800-698-5757

## Listen to KFNF and the MidAmerica Ag Network

With individual reports from area elevators and **Larry Steckline** as he tracks wheat harvest through Kansas and Southwest Nebraska.

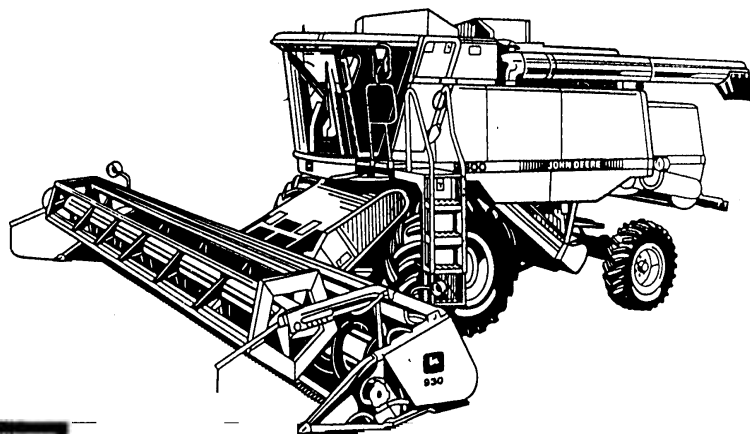

**Your  
Ag News  
Connection**



Highway 36 Oberlin, Kansas Phone 785-475-3638

☆ Buy a large Pizza at regular price and get a P-Zone pizza for **\$2.99**



Open Daily  
11 A.M.

Welcome to our Hut!



# Harvest Countdown

**\$100 in spendable scrip money!**  
*Register as often as you like  
 at all participating businesses!*

## Adaptable peonies grow well in Kansas

Peonies are the one plant we can all grow and enjoy. It has to be the all time workhorse of the garden. It is always so good to see their red sprouts peeking up through the ground in early spring. The fragrance and beauty of those big blossoms is such a treat, and the green foliage of the plant acts as a filler and background all summer until frost finally cuts them down.

**Master Gardener**  
*By Shirley Shields*

There are two groups of peonies, herbaceous and tree. Tree peonies grow to eye level on woody stems with few branches. The stems of these peonies stay alive during the winter and bloom early. Although their blooms come in a broader spectrum of colors, they are less common because they require more care and are more expensive.

petals. Semi doubles are a mass of loose petals and stamens scattered throughout the bloom.

Doubles are very full flowers, and the bomb peonies are characterized by narrow guard petals surrounding a pompon tuft of dense petals.

Herbaceous peonies are much more common, and do well in our soil and climate. The flowers are grouped into five primary types according to the shape of the petals. These are single, Japanese, anemone, semi double, double and the secondary bomb.

My tree peony bloomed the first part of May. The foliage is lovely and the single pink blooms are about eight inches in diameter. The Japanese has not yet bloomed, but last year the blossom held up well. They do not fall over like the double. It did dry up late last summer, but looks great this spring.

The peony "Kansas" is a bomb, and truly a favorite of mine for drying. It is a fairly old one but still readily available.

The extension office has a really good bulletin called "Peonies in the Garden." It contains information on fertilizing your plants, and cutting and storage for home and cemetery.

**Ready to Serve Your 2003 Grain Storage Needs!**



Colby • Dresden • Gem • Hoxie  
 Lenora • Selden

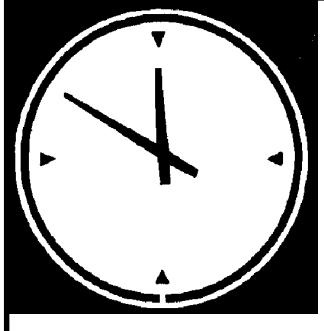

**It's high time to get CROP HAIL** protection for your crops. Crop Insurance Service  
**Coverage in effect within 2 hours.**

**Fredrickson Insurance Agency**  
 Tammy Fredrickson, agent  
 Oberlin, Kan. — Selden, Kan.  
**800-321-5063**



**Extension Lines**

*By Byron Hale*  
 Decatur County Extension Agent

## Bark beetles can attack cedars and windbreaks

Drought and bark beetles are an unhealthy combination in windbreaks, many of which have dead or dying trees. Kansas Forest Service is recommending owners of unhealthy windbreaks take action this spring and summer. The extended drought has put cedar trees in a stressed state. Bark beetles, which prey on weakened trees, have moved in and are killing these cedars.

the limbs and trunk must be saturated to kill the bark beetle.

Bark beetles may be referred to as shot beetles, shot hole borers, engraver beetles, or European Elm Bark Beetles. They are tiny beetles only 1/8-inch long, often choose conifers and hardwoods that are under stress, and are extremely destructive.

Dead and declining windbreak trees should be cut down and burned. Spraying windbreaks is not an effective control, as most spraying methods are foliar. The bark of

Recent rains have helped with the drought, however, additional watering may be needed to keep windbreaks alive. Kansas Forest Service is recommending that they be watered 10 to 12 hours a setting twice a month.

**STATE FARM'S FARM AND RANCH INSURANCE**  
 A PACKAGE OF PROTECTION  
 STATE FARM INSURANCE  
 Ken Schultz, agent  
 126 S. Penn, Oberlin (785) 475-2911  
 1-800-877-2251

**Harvest Time Combine Parts & Service ON-THE-FARM Inspection**  
 Call early for details or to make an appointment.  
**Southwest Implement**  
 1-800-794-9550  
 126 N. Penn — Oberlin, Kansas — (785) 475-3833

**Decatur County Implement is stocked up for harvest with all your Gleaner Combine Parts.**  
 Roller Chains & Bearings for all Makes  
**213 S. Penn Oberlin**  
**(785) 475-2254**

**Valspar Integrity** by Supermix Premium Exterior Latex Flat House Paint  
**\$15.97** gal. Reg. 21.99  
 • One Coat  
 • Excellent Adhesion  
 • Easy Water Clean-Up  
 • 20 Year Warranty  
**Stanley Best Hardware**  
 Joe and Regina Stanley, owners  
 149 S. Penn — Oberlin, Kan. (785) 475-2331

*See us for your fertilizer and chemical needs.*  
**Decatur COOP Assn. Crop Production**  
**East Hwy 36 — 785-475-3514**  
 Oberlin—Jennings—Kanona—Herndon  
 Ludell—Danbury, NE—Edmond

**HOME DECORATOR® LATEX FLAT WALL PAINT**  
 • Better quality  
 • Good hiding  
 • Durable, washable  
 • For living rooms, dining rooms, bedrooms  
**\$13.99** per gal.  
**\$14.99** Latex Eggshell  
**\$15.99** Latex Satin Gloss Enamel  
  
**Home Planning Center**  
 180 South Penn, Oberlin — 785-475-2325

**SPECIAL FOR THIS WEEK**  
 SUNDAES  
 REGULAR SMALL \$1.10 NOW 90¢  
 REGULAR LARGE \$1.70 NOW \$1.00  
 We now accept these cards for your convenience:  
  
 Family-owned / operated since 1906  
**DRUG STORE**  
**Addleman**  
 Phone 475-2661 — Oberlin — Toll Free 1-800-794-3784  
 Service and value are the cornerstones of our business.

*Wishing everyone a bountiful harvest*  
 Attorneys at Law  
**STEVEN W. HIRSCH**  
**PRESTON A. PRATT**  
 Licensed in Nebraska & Kansas  
 • GENERAL PRACTICE  
 • ESTATE PLANNING  
 • WILLS • TRUSTS  
 • PROBATE  
 124 S. Penn — Oberlin, Kansas — 785-475-2296

**Harvest is Near**  
**SHUR-LOK ROLL UP TARP**  
 The Wheat looks good — Does your tarp?  
 Call NOW to Schedule!  
**Gorman Tarps** 475-8919 (888) ROL-TARP

**The Stamps**  
 You Can't Wait to Get Your Hands On.  
 • PRE-INKED (NO STAMP PAD NEEDED)  
 • CLEANER, EASIER TO USE  
 • 50,000 IMPRESSIONS BEFORE RE-INKING  
 • DOZENS OF MODELS  
**THE OBERLIN HERALD**  
 170 S. Penn • Oberlin, Kan. 67756  
 785-475-2206